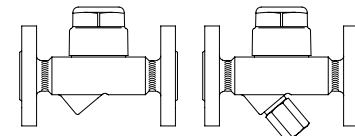


Thermodynamic steam trap

Thermodynamic steam trap

PN40

- with flanges (Fig. 640/641....1)
- with screwed sockets (Fig. 640/641....2)
- with socket weld ends (Fig. 640/641....3)
- with butt weld ends (Fig. 640/641....4)



Forged steel  
High temperature steel  
Stainless steel

Fig. 640/641 (Y)

Page 2

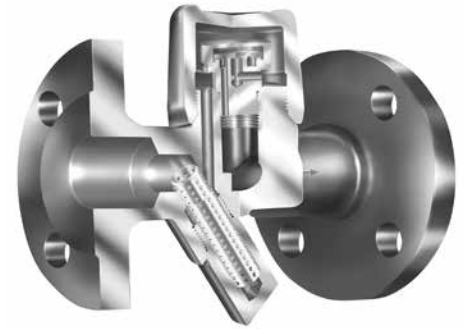
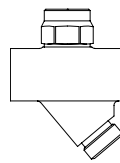


Fig. 641....1

Thermodynamic steam trap

PN63

- with screwed sockets (Fig. 641....2)
- with socket weld ends (Fig. 641....3)



Stainless steel

Fig. 641 (Y)

Page 4

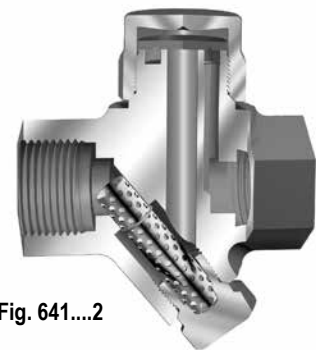
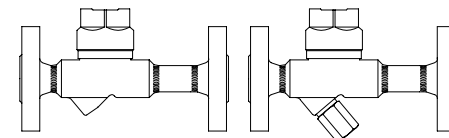


Fig. 641....2

Thermodynamic steam trap

PN63

- with flanges (Fig. 640/641....1)
- with socket weld ends (Fig. 640/641....3)
- with butt weld ends (Fig. 640/641....4)



High temperature steel

Fig. 640/641 (Y)

Page 6

**Features:**

- For discharging of slight to highly sub-cooled condensate
- Intermittent mode of operation
- Robust and resistant to water-hammer
- Integrated non return protection
- Constructions:
  - With inside strainer - Fig. 640
  - With outside strainer - Fig. 641 (Y)
- Optimized design for quick installation
- Gasket-free sealing of the screwed cap
- Installation in any position
- Heat chamber minimizes the impact of weather conditions on the trap's performance (except Fig. 56.641)
- Replaceable controller-unit

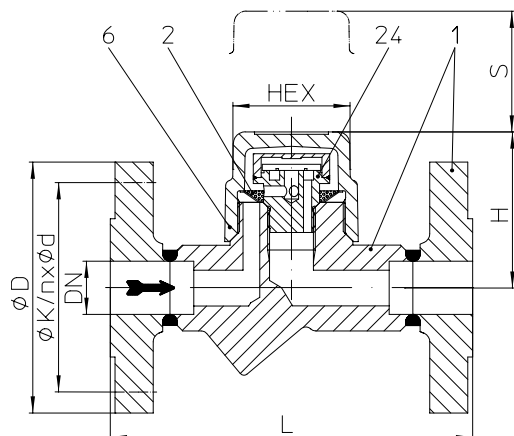
**Thermodynamic steam trap (Forged steel, High temperature steel, Stainless steel)**


Fig. 640....1 with flanges

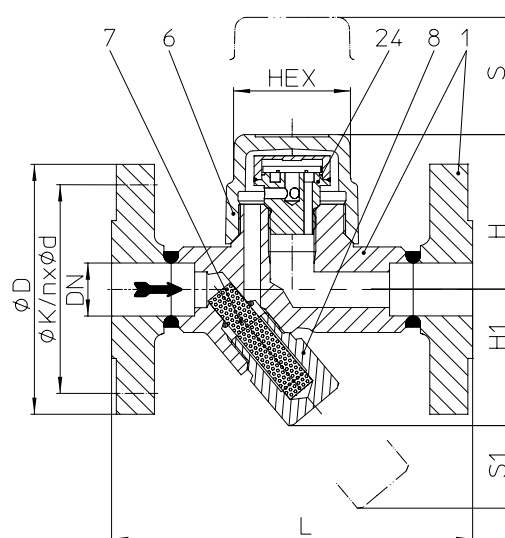


Fig. 641....1 with flanges

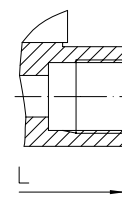


Fig. 640/641....2 with screwed sockets

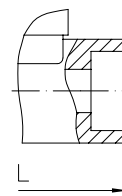


Fig. 640/641....3 with socket weld ends

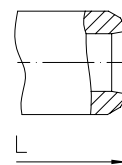


Fig. 640/641....4 with butt weld ends

Figure	Nominal pressure	Material	Nominal diam. / NPS	Operating pressure PS	Inlet temperature TS	Allow. differential pressure $\Delta PMX$	perm. pressure ratio / min. operating pressure
45.640 45.641 (Y)	PN40	1.0460	15 - 25 / 1/2" - 1"	32 barg	250 °C	32 bar	<b>perm. pressure ratio:</b> Back pressure / Inlet pressure $\leq 0,8$ barg <b>min. operating pressure:</b> 0,7 barg
				22 barg	385 °C		
				14,5 barg	450 °C		
85.640 85.641 (Y)	PN40	1.5415	15 - 25 / 1/2" - 1"	35 barg	300 °C		
				32 barg	335 °C		
				28 barg	450 °C		
55.640 55.641 (Y)	PN40	1.4541	15 - 25 / 1/2" - 1"	32 barg	350 °C		
				22 barg	400 °C		

For ANSI versions refer to data sheet CONA®TD-ANSI

**Types of connection**

Other types of connection on request.

- Flanges ....1 \_\_\_\_\_ acc. to DIN EN 1092-1
- Screwed sockets ....2 \_\_\_\_\_ Rp thread acc. to DIN EN 10226-1 or NPT thread acc. to ANSI B1.20.1
- Socket weld ends ....3 \_\_\_\_\_ acc. to DIN EN 12760
- Butt weld ends ....4 \_\_\_\_\_ Weld preparation acc. to EN ISO 9692 identification No. 1.3 and 1.5 (Note restriction on operating pressure / inlet temperature depending to design!)

**Features**

- Thermodynamic steam trap with replaceable controller-unit and cap with heat chamber wich minimize the effects from the weather conditions to the function of the trap such as low ambient temperatures, rain, wind, etc.
- Intermittent mode of operation
- Heat chamber minimizes the impact of weather conditions on the trap's performance
- Robust and resistant to water-hammer
- Integrated non return protection
- With inside strainer - BR640 / With outside strainer - BR641 (Y)
- Installation in any position
- Optimized design for quick installation
- Maintenance simplified due to screwed cap without sealing

**Options**

- Outside strainer with blow down valve (Pos. 46)

Types of connection	Flanges			Screwed sockets Socket weld ends			Butt weld ends		
	DN	15	20	25	15	20	25	15	20
NPS	1/2"	3/4"	1"	1/2"	3/4"	1"	1/2"	3/4"	1"

Face-to-face acc. to data sheet resp. customer request										
L	(mm)	150	150	160	95	95	95	250	250	250

Dimensions		Standard-flange dimensions refer to page 9.								
H	(mm)	65	65	65	65	65	74	65	65	65
H1	(mm)	62	62	62	62	62	55	62	62	62
S	(mm)	40	40	40	40	40	40	40	40	40
S1	(mm)	24	24	24	24	24	13	24	24	24
HEX	(mm)	50	50	50	50	50	50	50	50	50

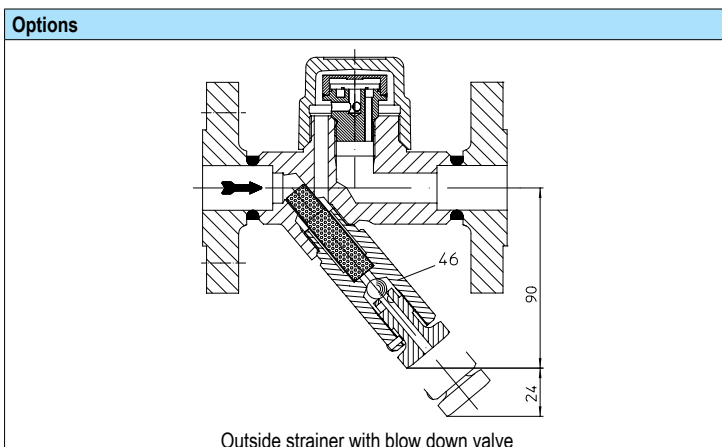
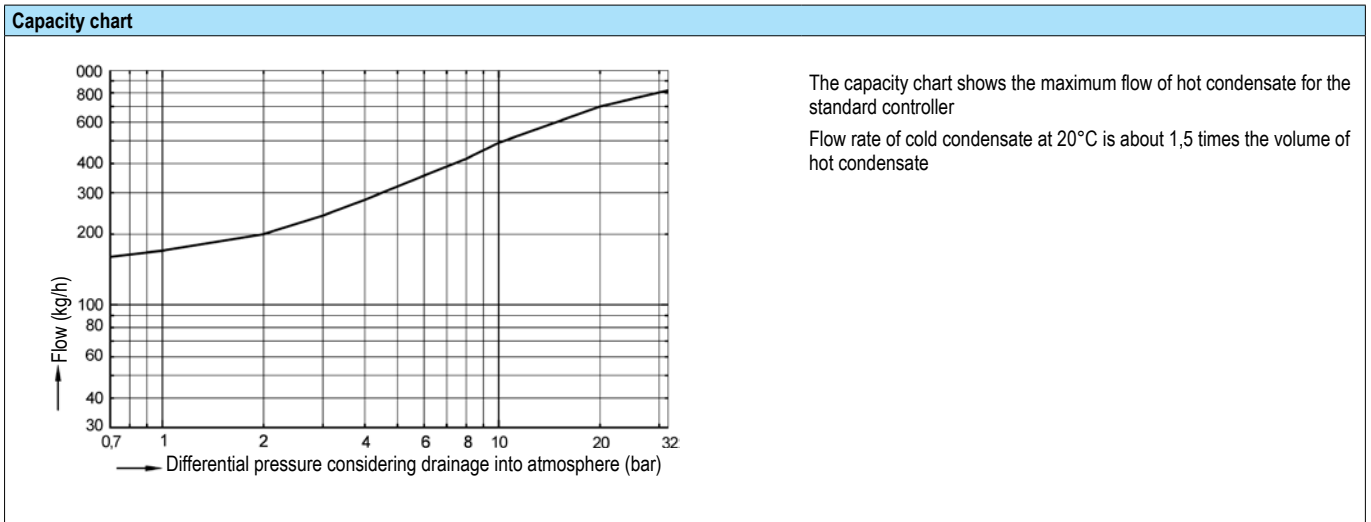
Weights										
Fig. 640 / 641(app.)	(kg)	2,7	3,3	3,7	1,4	1,3	1,8	1,8	1,9	2

Parts					
Pos.	Sp.p.	Description	Fig. 45.640 / 45.641	Fig. 85.640 / 85.641	Fig. 55.640 / 55.641
1		Body	P250 GH, 1.0460	16Mo3, 1.5415	X6CrNiTi18-10, 1.4541
2	x	Strainer	X5CrNi18-10, 1.4301		
6		Cap	P250 GH, 1.0460	16Mo3, 1.5415	X6CrNiTi18-10, 1.4541
7	x	Strainer	X5CrNi18-10, 1.4301		
8	x	Strainer plug	X6CrNiTi18-10, 1.4541		
24	x	Controller, cpl.	X39CrMo17-1+QT, 1.4122+QT		
46	x	Blow down valve, cpl.	X8CrNiS18-9, 1.4305		
L Spare parts					

Information / restriction of technical rules need to be observed!

Resistance and fitness must be verified (contact manufacturer for information, refer to Product overview and Resistance list).

Operating and installation instructions can be downloaded at [www.ari-armaturen.com](http://www.ari-armaturen.com).



## Thermodynamic steam trap (Stainless steel)

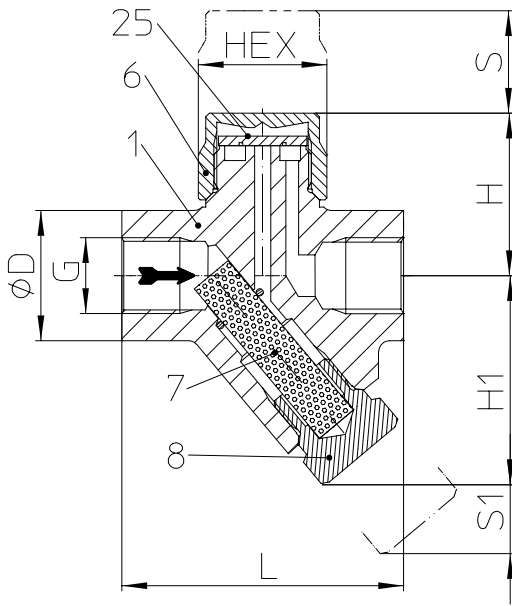


Fig. 641....2 with screwed sockets

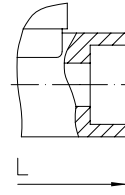

 Fig. 641....3  
 with socket weld ends

Figure	Nominal pressure	Material	Nominal diam. / NPS	Operating pressure PS	Inlet temperature TS	Allow. differential pressure ΔPMX	perm. pressure ratio / min. operating pressure
56.641 (Y)	PN63	A743CA40	3/8"-3/4"	42 barg	400 °C	42 bar	<b>perm. pressure ratio:</b> Back pressure / Inlet pressure ≤ 0,8 barg <b>min. operating pressure:</b> 1 barg
		1.4006	1"				

For ANSI versions refer to data sheet CONA®TD-ANSI

**Types of connection**

Other types of connection on request.

- Screwed sockets ....2 \_\_\_ Rp thread acc. to DIN EN 10226-1 or NPT thread acc. to ANSI B1.20.1
- Socket weld ends ....3 \_\_\_ acc. to DIN EN 12760

**Features**

- Thermodynamic steam trap of stainless steel for the condensate-discharge from all kinds of steam systems
- Intermittent mode of operation
- Robust and resistant to water-hammer
- Integrated non return protection
- With outside strainer
- Installation in any position
- Optimized design for quick installation
- Maintenance simplified due to screwed cap without sealing

Types of connection	Screwed sockets (NPS 3/8" - 1")			
	--	Socket weld ends (DN 15-20)		--
DN	10	15	20	25
NPS	3/8"	1/2"	3/4"	1"

Face-to-face acc. to data sheet resp. customer request					
L	(mm)	78	78	90	95

Dimensions		Standard-flange dimensions refer to page 9.			
H	(mm)	47	47	50	59
H1	(mm)	56	56	56	61
S	(mm)	20	20	20	20
S1	(mm)	45	45	45	45
HEX	(mm)	32	32	32	41

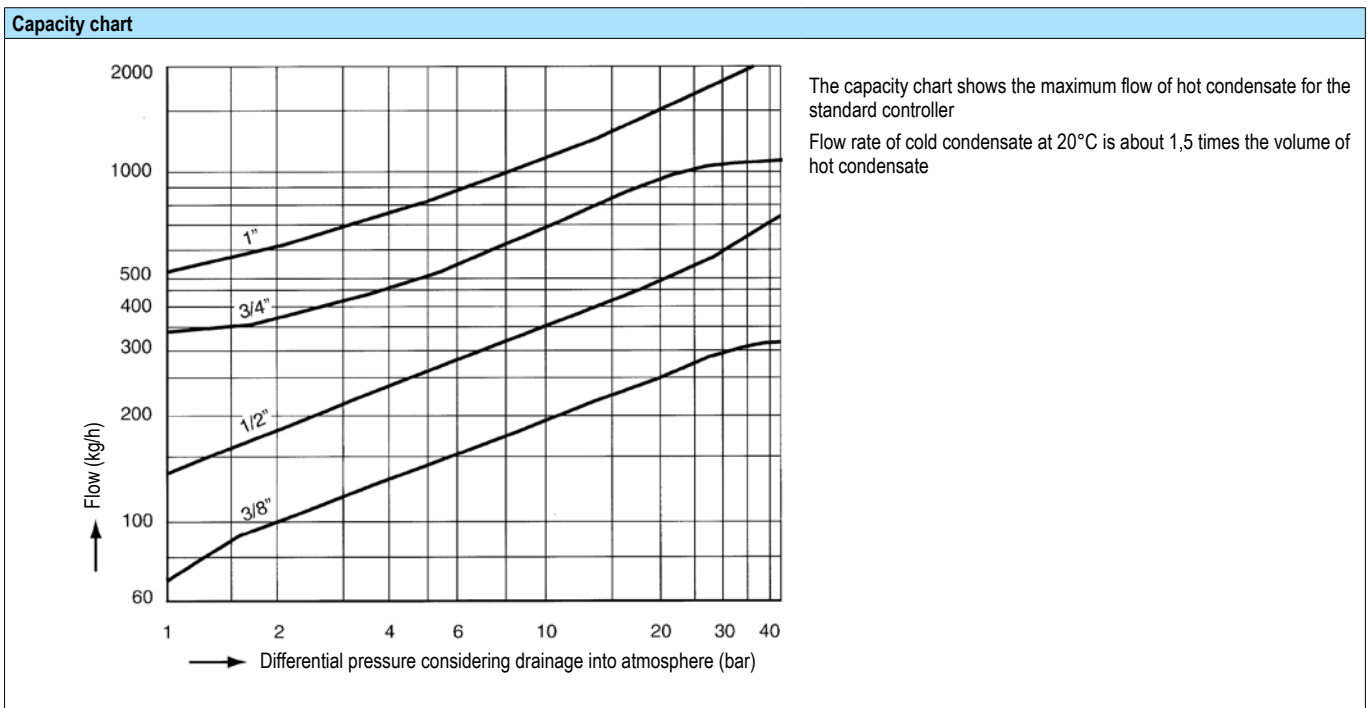
Weights					
Fig. 641 (approx.)	(kg)	0,8	0,8	0,8	0,9

Parts				
Pos.	Sp.p.	Description	Fig. 56.641	
			NPS 3/8" - 3/4"	NPS 1"
1		Body	A743CA40	X12Cr13, 1.4006
6		Cap	X8CrNiS18-9, 1.4305	
7	x	Strainer	X5CrNi18-10, 1.4301	
8		Strainer plug	X6CrNiTi18-10, 1.4541	
25	x	Disc	X39CrMo17-1+QT, 1.4122+QT	
L Spare parts				

Information / restriction of technical rules need to be observed!

Resistance and fitness must be verified (contact manufacturer for information, refer to Product overview and Resistance list).

Operating and installation instructions can be downloaded at [www.ari-armaturen.com](http://www.ari-armaturen.com).



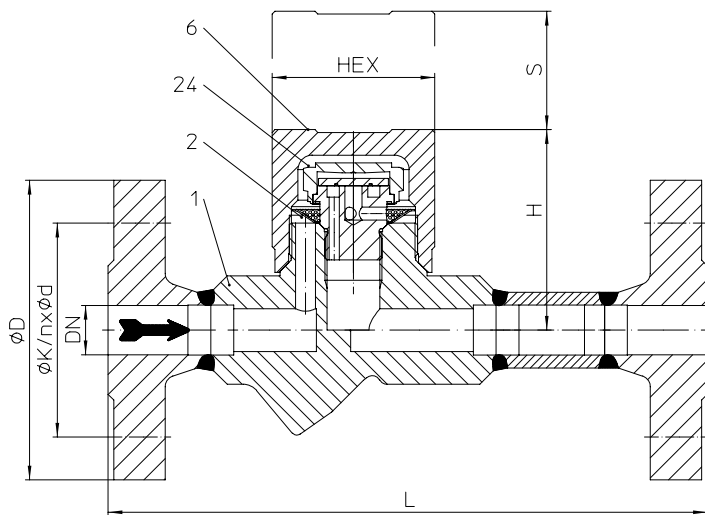
**Thermodynamic steam trap (High temperature steel)**


Fig. 640....1 with flanges

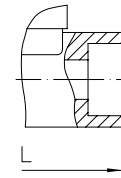
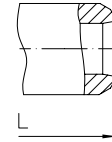
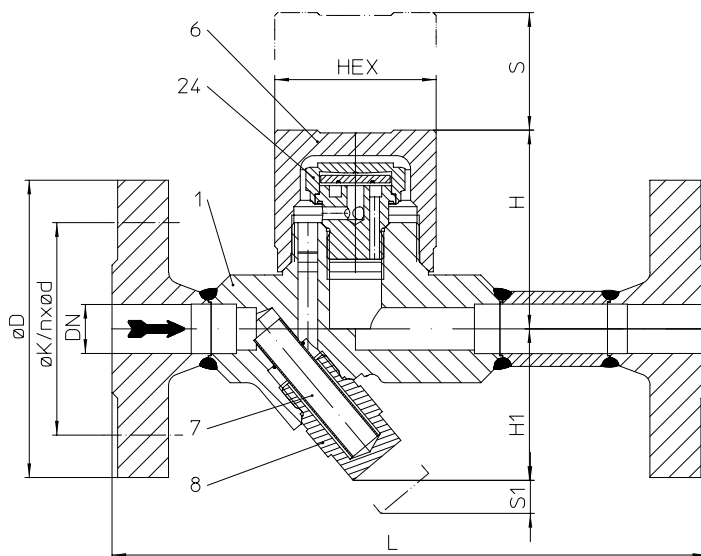

 Fig. 640/641....3  
with socket weld ends

 Fig. 640/641....4  
with butt weld ends


Fig. 641....1 with flanges

Figure	Nominal pressure	Material	Nominal diam. / NPS	Operating pressure PS	Inlet temperature TS	Allow. differential pressure $\Delta$ PMX	perm. pressure ratio / min. operating pressure
86.640 86.641 (Y)	PN63	1.5415	15 - 25 / 1/2" - 1"	42 barg	450 °C	42 bar	perm. pressure ratio: Back pressure / Inlet pressure $\leq 0,8$ barg min. operating pressure: 0,7 barg

For ANSI versions refer to data sheet CONA®TD-ANSI

**Types of connection**

Other types of connection on request.

- Flanges ....1 \_\_\_\_\_ acc. to DIN EN 1092-1
- Socket weld ends ....3 \_\_\_\_\_ acc. to DIN EN 12760
- Butt weld ends ....4 \_\_\_\_\_ Weld preparation acc. to EN ISO 9692 identification No. 1.3 and 1.5  
(Note restriction on operating pressure / inlet temperature depending to design!)

**Features**

- Thermodynamic steam trap with replaceable controller-unit and cap with heat chamber wich minimize the effects from the weather conditions to the function of the trap such as low ambient temperatures, rain, wind, etc.
- Intermittent mode of operation
- Heat chamber minimizes the impact of weather conditions on the trap's performance
- Robust and resistant to water-hammer
- Integrated non return protection
- With inside strainer - BR640 / With outside strainer - BR641 (Y)
- Installation in any position
- Optimized design for quick installation
- Maintenance simplified due to screwed cap without sealing

Types of connection	Flanges			Socket weld ends			Butt weld ends <sup>1)</sup>		
DN	15	20	25	15	20	25	15	20	25
NPS	1/2"	3/4"	1"	1/2"	3/4"	1"	1/2"	3/4"	1"

<sup>1)</sup> Please indicate dimension of the tube when ordering

Face-to-face acc. to data sheet resp. customer request										
L	(mm)	210	210	230	95	95	95	250	250	250

Dimensions										Standard-flange dimensions refer to page 9
H	(mm)	65	65	65	65	65	74	65	65	65
H1	(mm)	62	62	62	62	62	55	62	62	62
S	(mm)	40	40	40	40	40	40	40	40	40
S1	(mm)	24	24	24	24	24	13	24	24	24
HEX	(mm)	50	50	50	50	50	50	50	50	50

Weights											
Fig. 640 / 641	(approx.)	(kg)	3,7	5,2	6,6	1,3	1,2	1,7	1,8	1,9	2,0

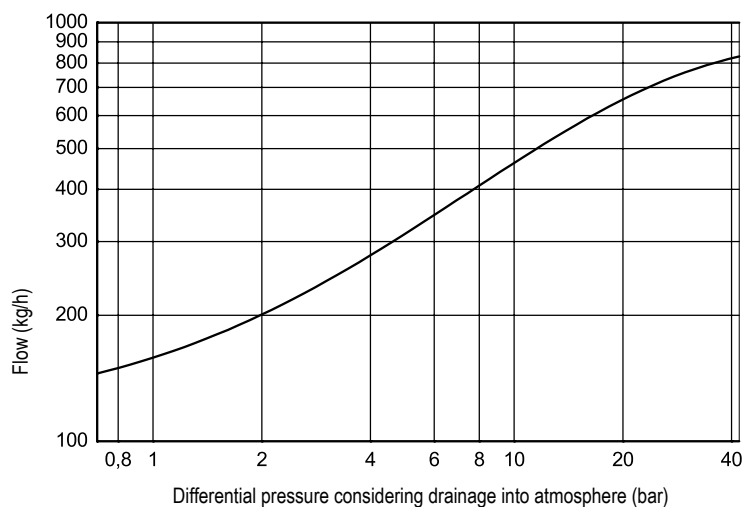
Parts										
Pos.	Sp.p.	Description	Fig. 86.640	Fig. 86.641						
1		Body	16Mo3, 1.5415							
2	x	Strainer	X5CrNi18-10, 1.4301	--						
6		Cap	16Mo3, 1.5415							
7	x	Strainer	--	X5CrNi18-10, 1.4301						
8	x	Strainer plug	--	X6CrNiTi18-10, 1.4541						
24	x	Controller, cpl.	X39CrMo17-1+QT, 1.4122+QT							
		L Spare parts								

Information / restriction of technical rules need to be observed!

Resistance and fitness must be verified (contact manufacturer for information, refer to Product overview and Resistance list).

Operating and installation instructions can be downloaded at [www.ari-armaturen.com](http://www.ari-armaturen.com).

### Capacity chart

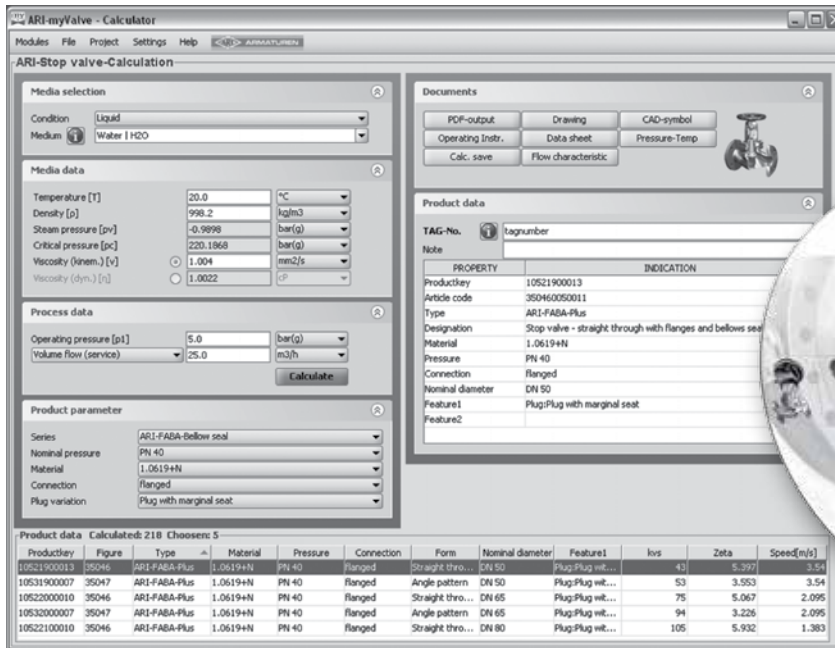


The capacity chart shows the maximum flow of hot condensate for the standard controller

Flow rate of cold condensate at 20°C is about 1,5 times the volume of hot condensate

**myValve® - Your Valve Sizing-Program.**

myValve is a powerful software tool that not only helps you size your system components; it also gives you instant access to all other data about the selected product, such as order information, spare parts drawings, operating instructions, data sheets, etc., whenever you need it.


**myValve - Valve Sizing-Program**
**Contents:**
**Module ARI-Steam trap CONA-Calculation**

- Sizing (calculation of steam trap systems with given flow capacity or heat capacity)
- Calculation of nominal diameter acc. to given pressure, condensate quantity, condensate sub-cooling and speed

**Media:**

- Steam (saturated and superheated)
- Compressed air

**Special Features**

- Project administration of the calculation and product data incl. spare part drawings concerning to project and tag number
- Direct output or calculation and product data in PDF format
- Product data could be taken for a direct order
- SI- and ANSI-units with direct conversion to another databank
- Settings with over pressure or absolute pressure
- All ARI products are integrated in one databank
- Direct access concerning to the product on data sheets, operating instructions, pressure-temperature-diagram and spare part drawings
- Operation in company networks possible (no complex installations on individually PC's necessary)
- Extensive catalogue extending over several product groups

**System Requirements:**

Windows operating systems, Linux, etc.



**Informations about pipe welding**
**Welding groove acc. to DIN 2559**

The material used for ARI valves with butt weld ends are:

1.0460 P250GH acc. to DIN EN 10222-2

1.5415 16Mo3 acc. to DIN EN 10222-2

**Note:**

A743CA40 acc. to ASTM A743/A743M-98a

Note restriction on operating pressure / inlet temperature depending to design! 1.4006 X12Cr13 acc. to DIN EN 10250-4

Due to our experience, we recommend to apply an electric welding process.

Because of the different material compositions and wall thickness of the steam traps and the pipe gas welding shall not be applied. Quenching cracks and coarse grain structure may develop.

Steam traps with socket-weld ends shall only be welded by arc welding (welding process 111 acc. to DIN EN 24063).

If during the time of warranty others than the manufacturer or by the manufacturer authorized persons are interfering in the product and/or the setting, the right of claim for warranty will lapse!

**Standard-flange dimensions acc. to DIN EN 1092-1**

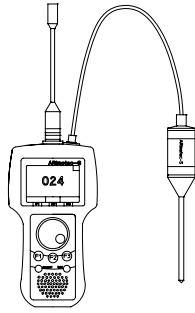
DN			15	20	25
NPS			1/2"	3/4"	1"
PN40	ØD	(mm)	95	105	115
	ØK	(mm)	65	75	85
	n x Ød	(mm)	4 x 14	4 x 14	4 x 14
PN63	ØD	(mm)	105	130	140
	ØK	(mm)	75	90	100
	n x Ød	(mm)	4 x 14	4 x 18	4 x 18

**Selection criteria:**

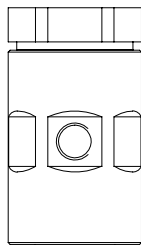
- Steam pressure
- Back pressure
- Quantity of condensate
- Nominal diameter / pressure
- Type of connection
- Material
- Place of service or kind of steam consumer

**Example for order data:**

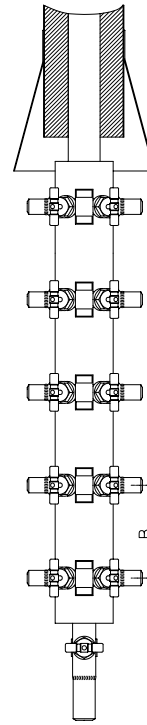
**Thermodynamic steam trap CONA® TD,  
Fig. 640, PN 40, DN 15, 1.0460, with flanges, Face-to-face dimension 150 mm**



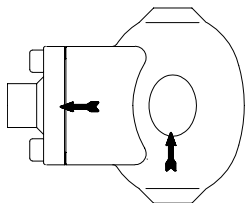
Multifunction tester  
**ARImetec®-S**



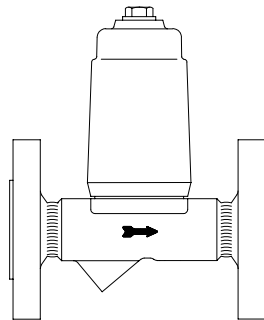
Vacuum breaker  
Fig. 655



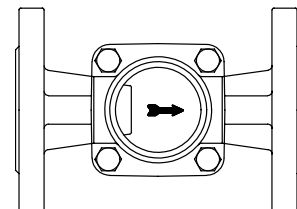
Condensate collection (B = 160), steam distribution (B = 120)  
**CODI®S** with gland packing Fig. 671/672;  
**CODI®B** with bellows seal, maintenance-free Fig. 675/676



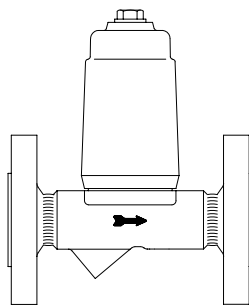
Automatic air vent for liquid systems  
Fig. 656



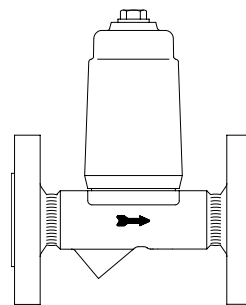
Condensate discharge temperature limiter  
Fig. 645/647



Flow indicator  
Fig. 660/661



Return temperature limiter  
Fig. 650



Liquid drainer  
Fig. 665

(Further informations about the accessories can be found in the appropriate data sheets.)